



**Radio-Sync, Constant Color**

# **POWERLIGHT®**

**Operator's Manual**

Solair® Constant Color PLR500DR  
Solair® Constant Color PLR1000DR  
Voltage Smart™ Solair® PLRX500DR  
Voltage Smart™ Solair® PLRX1000DR  
&  
Remote Studio Control Accessories

## OPERATOR MANUAL FOR MONOLIGHTS

# Solair®

Radio-Sync, Constant Color  
PLR500DR & PLR1000DR

Voltage Smart™, Radio-Sync, Constant Color  
PLRX500DR & PLRX1000DR

### INFRARED ACCESSORIES

**PLCPTR-2** Computer Control Software.

**PLDIR-2** Side display & IR receiver.

**PLIRC-1** Hand held remote control.

Thank you for selecting the Photogenic Professional PowerLight *Solair* brand, *Radio-Sync, Constant-Color* series. The *Solair Radio-Sync, Constant-Color* series incorporates the newest electronic technology providing improved lighting control, power setting repeatability and expanded functions. These products are built for the demanding operational needs of the professional photographer and it is our expectation that your PowerLight and PowerLight accessories will provide you with years of dependable service. The *Voltage Smart Solair Radio-Sync, Constant Color* models permit use of worldwide voltages and frequencies. With these two new *Solair Radio-Sync, Constant-Color* series optional accessories include: remote power displays, infrared remote control and computer software to control and save your flash and modeling studio group light settings.

### INTRODUCTION

The Solair PowerLights are a self-contained light unit and power supply. They have a professional plug-in flashtube, a 250 watt adjustable quartz modeling light, and bare bulb capability, both vertically and horizontally. The PowerLights are fitted with Photogenic's unique quick-change system for holding accessories made by Photogenic Professional Lighting.

Before using your new PowerLight for the first time, please read this manual carefully and acquaint yourself with the controls and features. In this way, you can quickly get the greatest benefit from your new unit and maintain an efficient and safe operation.

## **SAFETY PRECAUTIONS**

Despite the measures that have been taken to make electronic flash equipment safe, it must be recognized that high voltages and high temperatures do exist within the power supply / lighting unit. Certain precautions must be observed in handling the unit. **Contact with internal high voltage may result in severe injury or death.**

1. Before installing or removing the flashtube and modeling lamp, be sure this appliance is turned off, cooled and unplugged from AC power source.
2. Do not touch the glass tubes with bare hands, as normal body oils will shorten the bulb's life. Always use a clean cloth or wear gloves to protect your hand from glass breakage and heat.
3. Do not defeat the purpose to the three-wire line cord by disconnecting the ground. Connect to properly functioning and grounded 3-pin receptacles only. If you are using an extension cord, be sure the cord has an equivalent or greater rating and has a ground.
4. Do not insert a screwdriver or other metal objects into the flashtube socket area or vents. Contact with high voltage may result.
5. Do not operate this appliance with a frayed or damaged line cord. When replacing or using the unit with an extension cable, be sure the cable has an equivalent or greater rating and is a properly connected 3-wire grounded cable.
6. Do not attempt to use this appliance if it has been dropped or damaged, until a qualified service person has serviced it.
7. Do not operate the unit with a damaged or broken flashtube or modeling lamp. Do not use flashtubes with broken, cracked or missing glass envelopes. To prevent damage or injury always use Photogenic specified replacements for the flashtubes and modeling lamps.
8. Perform no internal service work on this unit. Refer all such service to a qualified service person or return to the factory. This will provide you safety and continuation of your warranty.
9. Do not operate when water is present and from extreme temperature shifts. If the unit is stored in hot or below freezing temperatures, allow at least one hour at room temperatures before using.

## **PREPARATION AND BASICS**

### **Unpacking and Setup:**

Unpack all units carefully to remove all parts from the carton(s). Do not discard or destroy the packing material until the equipment has been inspected, assembled, and all parts accounted for.

After unpacking, all parts should be examined for any damage, which may have been caused by rough handling during shipment. If any damage is detected, contact the delivering carrier at once. Claim for damage should be made to the delivering carrier before destroying packing cartons.

To set up the unit, first mount and secure it on a suitable stand. The PowerLight stand adapter allows the unit to be mounted on a stand with a 3/8" to 5/8" post. Be sure to use a stand that is stable and will not tip easily.

The unit is shipped with the modeling lamp and flashtube not installed. While installing the modeling lamp and flashtube (with glove or clean cloth to protect the hand and tube) be sure they are properly inserted and tight to avoid arcing and failure of the socket contacts during operation. Do not touch the glass tubes with bare hands, as normal body oils will shorten the bulb's life. Always use a clean cloth or wear gloves to protect your hand from glass breakage and heat.

The 7 \_ inch reflector is attached by the "quick-change" mechanism. Three tabs on the unit grip the ring on the reflector. Finger levers located on the top of the unit control two of these tabs. To mount the reflector, squeeze the finger levers towards each other and tilt the reflector past the stationary top-tab, then past the two tabs that are controlled with the levers. Release the finger levers and make sure all three tabs are securing the reflector (see illustration below.) All PowerLight accessory reflectors and soft boxes are designed for use with this "quick-change" system or onto this 7 \_ inch reflector

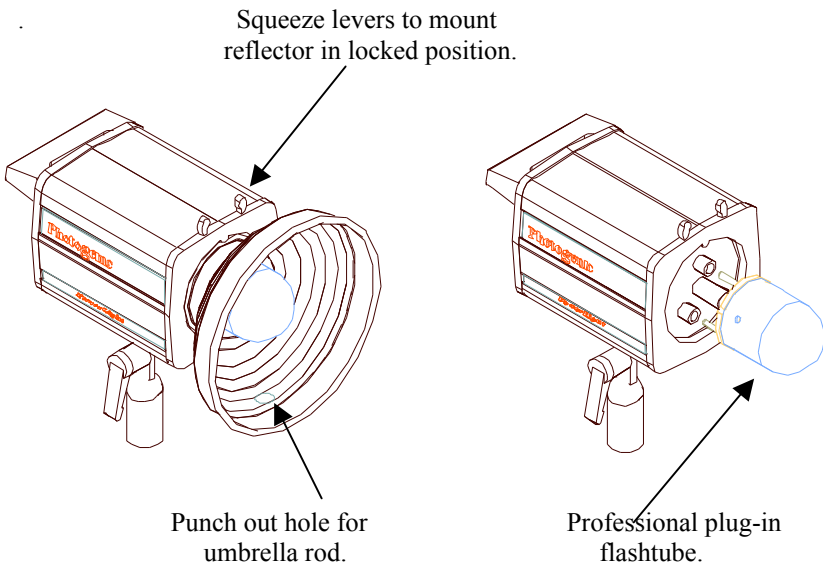

With power switch OFF, attach the line cord to the power-input connector, located on the bottom of the PowerLight, and connect it to a grounded wall outlet. Turn the power switch ON. The READY light will light when the unit has charged to the power level set by the FLASH power control.

## **DIGITAL CONTROL PANEL AND BASIC OPERATION:**

### **Power Input:**

The power required to operate the Solair Radio-Sync, Constant-Color PLR500DR or PLR1000DR is 105 to 125 volts AC, 60 Hz, 5 Amp. The power cord has a 125V, 15 Amp. rating. [The Voltage Smart Solair Radio-Sync, Constant-Color PLRX500DR or PLRX1000DR is rated 90 to 250 volts AC, 50/60 Hz, 3.5 Amp and has a 230V power cord with a German/European plug. These Voltage Smart units have no recharge line current surge.] Replacement cords or extension cords rated for less amperage may overheat and should not be used with PowerLights.

### **Circuit Protection:**

Circuit protection automatically protects this appliance from excessive damage due to circuit or component failure. Operation exceeding the rated cycle of the appliance may cause the fuse to open. [Always replace fuse with same rating of fuse.] An additional thermal protector is located inside the PowerLight and may open, if the rated duty cycle is exceeded. A cooling off period of 10 to 45 minutes is required to reset the thermal fuse. There is also protection in the microcontroller software which is designed to protect against exceeding the rated flash cycles. See **Diagnostic Display Codes:** below.

To replace a blown fuse (power cord must be disconnected), simply unscrew the fuse holder cap (bottom of unit) and replace the exposed fuse with a new fuse. If fuses continue to blow, contact your dealer or qualified service person. (See specification section for fuses replacements)

### **Power-Up display sequence.**

The processor will search the unit for functions that have been activated from the last time the light was used. As this search is done the first display reads "8888". Next in the search sequence is AC and Hertz and you will see 50 or 60 displayed. If Auto-Bracketing is active you will see =br= followed by the High "H" setting and then the Low "L" setting. The final standard sequence displays the unit number designated for the light, 1 through 9. When the search cycle is complete, the display will then show the setting for flash watt seconds.

"See Advanced Features & Diagnostic Display Codes.

# Functional Operation

## Solair®

### Radio-Sync, Constant-Color PLR500DR & PLR1000DR Voltage Smart,™ Radio-Sync, Constant-Color PLRX500DR & PLRX1000DR

#### Power Switch:

The power switch controls the AC power to both the modeling and flash circuits. You have the option to turn-off the modeling circuit independently.

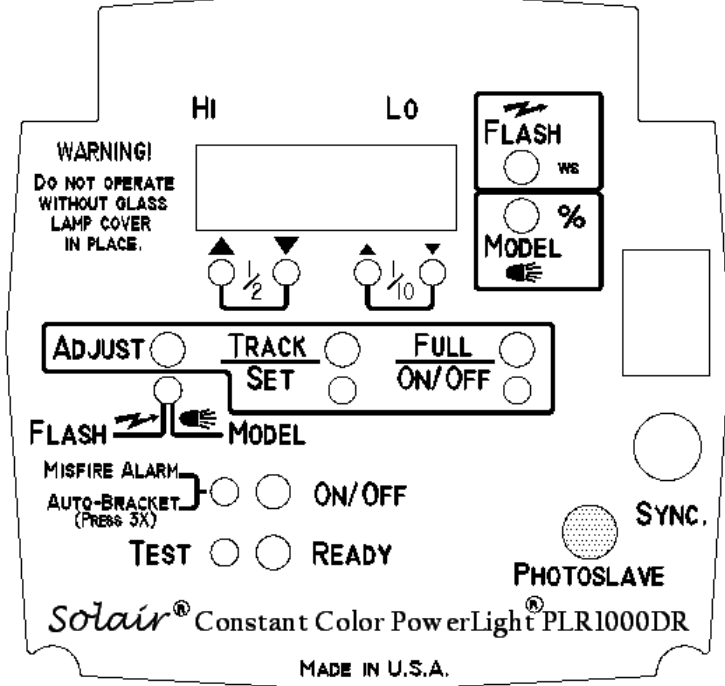

#### Flash Power:

When the power is turned on the red LED is illuminated. You adjust the PowerLight Flash power settings by pressing the 1/2 or 1/10 f-stops UP/DOWN arrow buttons. The watt second settings will be displayed. (If the *adjust* button is pressed again the modeling circuit and yellow LED will be turned on.)

#### Ready Light:

The Solair Radio-Sync, Constant-Color PLR1000DR & PLRX1000DR models are fully charged when the READY lamp is on. Lowest power (7.8ws) setting charge time is a maximum of .8 seconds and at full power charge (1000 ws) time is a maximum of 3 seconds. The unit may be flashed before fully charged. When adjusting flash power settings downward the units will bleed stored power until the lowered power setting is reached, the ready light will then be re-illuminated.

The Solair Radio-Sync, Constant-Color PLR500DR & PLRX500DR models are fully charged when the READY lamp is on. Lowest power (3.9ws) charge time is a maximum of .5 seconds and at full power charge (500 ws) time is a maximum of 1.5 seconds. The unit may be flashed before fully charged. When adjusting flash power settings downward the units will bleed stored power until the lowered setting is reached, the green READY light will then be re-illuminated.

**Audible READY:** The Solair models also have an audible ready feature that will announce that the stored power has reached the level you have displayed. This feature can be activated or deactivated by pressing and holding the TEST button until the green READY light blinks.

### **Modeling Light:**

The modeling light has three modes of operation:

1. MANUAL [press the MANUAL/ADJUST button to turn the MODEL yellow LED on] adjusts the modeling lamp intensity using the 1/2 or 1/10 f-stops UP/DOWN arrow buttons. Pressing the MANUAL/ADJUST button a second time will change the mode to flash adjustment and is indicated by the illuminated *red* LED

2. TRACK mode (Proportional modeling) causes the modeling lamp intensity to track the FLASH setting. The modeling lamp may be re-set to full intensity at any FLASH value, by simply pressing the TRACK/SET button a second time, with the FLASH already set to desired watt-seconds. This setting is retained when the user returns from another mode. [Tracking is limited to 6 f-stops.]

3. FULL ON/OFF is exactly what it says. Press the FULL ON/OFF button to turn the modeling lamp OFF (LED off) or FULL ON (LED on).

Note: All current mode settings are retained, even after the power is turned off.

### **Test Function:**

The TEST button is pressed to fire the flashtube for test purposes, to re-set after a misfire or to dump stored power when moving to a lower watt second level.

### **Misfire Indication:**

The display will show “- - -” if there is a misfire. Press the test button to reset. Additionally, the Solair PowerLights are equipped with audible alarm if the flash has not fired properly. This audible feature can be turned ON (LED on) or OFF (LED off) with the *Misfire/Auto bracket* button. To activate or deactivate this alarm feature press this button once. If the yellow light next to the button is illuminated this feature is ON.

### **Synchronization and Triggering:**

Triggering is accomplished by using a built-in **PocketWizard®** radio receiver, built-in photoslave or a trigger cable from the power supply to the camera shutter contacts of “X” or “zero” delay. Other units in the system are then triggered by photoslave operation. [All radio-sync PLR units can be triggered with the **PocketWizard® PLUS** transmitter.] It is best to connect the fill light directly to the camera since it will be positioned furthest back in the studio and will usually provide sufficient illumination to trigger the other units. It is suggested that all walls and ceiling be painted either in white or light neutral colors for most reliable photoslave operation.

After the trigger cord is properly connected, check the synchronization with a film camera. Adjust the lighting unit to same height as the camera lens and face the lights into the lens. The lens aperture should be open to its fullest extent and set on “X” or “zero” delay. Remove the camera back. It is best to perform this test with the modeling lamps turned off.

While looking at the lens through the back of a film camera, operate the shutter. A few sheets of white paper in front of the lens will cut down the brilliance of the flash and aid in making the observation. The flash of the light should then appear as a circle the same size as the aperture. If the circle is flattened on the sides, or if no light appears through the lens, the shutter is not synchronized. If the shutter appears not to be synchronized, a reputable camera repair shop should check the shutter contacts.

The sync polarity is Positive on center pin of cable connectors (Photogenic part PLTC, and defined in ISO 518.)

Sync voltage is 12 vdc (Spec. = less than 24 vdc per ISO 10330:1992E, and greater than 9 vdc for Wein photo slave at 10 microampere drain.) Internal 240 ohm discharge limit, with 68 k ohms continuous limit.

Sync signal = negative pulse, 10 microseconds or longer, from sync voltage to 1.6 vdc or less (per ISO 518.)

**PocketWizard® use:** The PowerLight built-in receiver is actually 16 channel useable. The PLUS transmitter is 4 channel. The PowerLight built-in sync radio receiver will hunt for a signal for 30 seconds after power is applied. If a minimum of four consecutive triggers are seen during that time period, the receiver will assume that channel. If no signal is seen, the receiver will operate on whatever channel it was set to before power was removed. So, turn on the Plus Transmitter and set the channel to 1, 2, 3 or 4. Make sure the local/both/remote switch is set to either both or remote. Hold the Test button (on Plus Transmitter) down and turn the PowerLight ON. Continue to hold the transmitter Test button down for 6 seconds. This should be sufficient time to teach the PowerLight receiver. When you press the Plus Transmitter Test button subsequently, the PowerLight will flash. Check transmitter instructions for proper connection to camera and other details. **To prevent the PowerLight photoslave from triggering the flash, you must insert a SYNC plug (or  $\frac{1}{8}$ ” diameter dowel rod) into the  $\frac{1}{8}$ ” sync jack.**



### **Photocell/Photo Slave:**

The sensor is built-in and can be shut off by plugging in the sync cord.

### **Flash Power Bracketing:**

Bracketing refers to taking up to three (3) exposures in a sequence with different flash intensities, either additional watt seconds or fewer watt seconds, from the displayed or selected “primary” base intensity. The Solair units enable you to set the base flash power and then one high and one low bracketing values. Once the setting(s) have been pre-set, a sequence of power levels will automatically occur as you take the exposures. If you wish to only bracket up from the primary, set a HIGH value and leave the LOW value at “0”. If you wish to only bracket down from the primary, set the HIGH value at “0” and set a LOW value.

The 3-exposure bracketing sequence is:

1. Primary power setting.
2. Higher power pre-set.
3. Lower pre-set.

The 2-exposure bracketing sequence is:

1. Primary power setting.
2. Either Higher or Lower (skips the “0” settings)

### **To set or change the Auto-Bracketing settings:**

1. Press the Auto-Bracketing button 3 times. This will cause the display to read “br”, then H. .0
2. Press the small up or down (1/10) button to set the HIGH value. The values can be set at zero “0” to “1.5” f-stops above the primary power setting.
3. Press the large up (1/2) button once. This will cause the display to read “L. .0
4. Press the small down or up (1/10) button to set the LOW value. The values can be set at zero “0” to “1.5” f-stops below the primary power setting.
5. Press the AUTO-BRACKET button to save these pre-sets.

### **To turn off the Auto-Bracketing settings:**

Setting both the HIGH and the LOW values at zero “0” will turn off the Auto-Bracket feature.

Note: The auto-bracketing settings are retained and sequenced until the feature is manually turned off. If the primary power setting is changed the Auto-Bracketing feature will continue to sequence using the pre-set HIGH and LOW values from the new primary level.

(This bracketing feature is limited by the 8 f-stops of total watt seconds available in each model.)

# Color Temperature

## Consistent and Constant

**The problem:** With the rare exception of units costing many thousands of dollars, flash lighting packs, up to now, do not control the color temperature of the light. The color temperature typically decreases by over 100 degrees Kelvin for every f-stop of power reduction. Over a 6-stop adjustment range, this results in a color temperature decrease of over 600K. Even units that have a small 3-stop range can produce significant color shifts of over 300 degrees. This can result in much larger shifts between two light sources than film can correct. (Kodak recommends less than 200 degrees shift between light sources for their 5500-degree daylight film.)

**The solution:** Photogenic has created an affordable solution to this problem. The new Solaris PowerLights provide consistent and constant color temperature across their amazing 8-stop range. Be wary of claims of *consistent* color temperature at only one power level. This is not the same as *constant-color* temperature over all power levels. Both are necessary to provide the perfect exposure we all strive for. The light produced by the new Solair is *consistent & constant*. Every time you key in a desired power level on the digital input, you will receive the same amount of light as you obtained previously, and at the same color temperature. The light produced by the new Solair is constant-color. No matter what power setting you select, the light will be the same color temperature. Using the standard color corrected flash lamp; every subject will be exposed to approximately 5400 degree Kelvin light, regardless of power setting. This solves forever the problem of unbalanced power settings in your studio, resulting in color temperature shifts in your pictures.

## Flash Duration

The Solair PowerLights provide motion-stopping capability ranging from 1/250-second flash duration at full power to 1/3700 at minimum power, eight stops down. Unlike shutter speed, flash duration can be reported in different ways. It is generally defined as the length of time light is produced above a certain power level. Photogenic Solair measurements are reported at the 1/10 power level or  $t = 0.1$ , instead of several other widely used methods.

While any point of the discharge curve can be utilized to measure the duration of a flash, the most commonly used are 1/10, 1/3, and 1/2 of peak. ‘Doc’ Edgerton [Edgerton, “Electronic Flash Strobe”, 1987, pg 30] recommended the 1/3-point be used for duration measurements in order to approximate the power being measured. While this has served the industry well for many years, the commonly available integrating power meter gives the exact amount of power delivered, and we no longer need to approximate this measurement. The 1/2

power point is commonly used in engineering and serves the purpose of reporting the bandwidth of the flash duration, but the graph below clearly shows that a power point measurement does not truly report the total flash duration. The clock doesn't start running until the flash discharge reaches 50% of its peak, and stops when it falls below 50%. Since the color temperature of the flash varies over time (more blue in the beginning and more red towards the tail [pgs 48-60]), it is important that flash duration be reported at the 1/10 power levels to express the total flash duration and not cut off any of the available flash power.

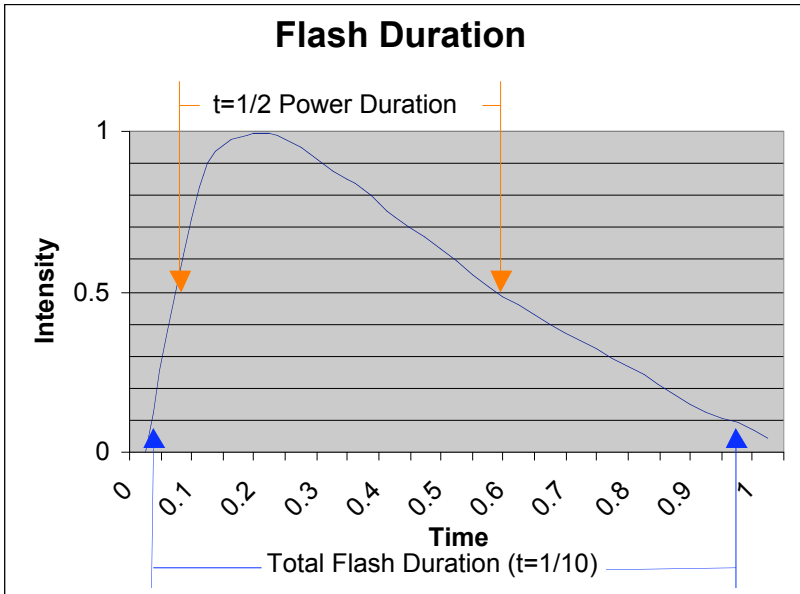

You can see that there is quite a bit of light which would be wasted, if we set our shutter speed to the duration using the  $t = 1/2$  technique. In effect, the flash duration is longer than you think it is — up to three times longer. So  $t = 1/2$  or  $t = 1/3$  are not really useful measurements, since we're used to thinking in terms of shutter speeds. We at Photogenic want you to get consistent and constant color temperature and all the flash power you paid for. That's why we report all Solair flash durations using the  $t=1/10$  technique. As you can see, setting your shutter speed to the  $t=0.1$  flash duration or greater will result in your camera capturing virtually all of the light available.

# Reciprocity Explained

*-Excerpts taken from Kodak TECHNICAL PUBLICATION DATA I FILM E31- July 2002*

The reciprocity law states that the *intensity* of light falling on a photographic film multiplied by the exposure *time* equals the total amount of *exposure*.

## **Intensity x Time = Exposure**

This means, for example, that an exposure of  $f 16$  at  $1/60$  second is equivalent to an exposure of  $f 11$  at  $1/125$  second. In either combination of settings, the same total amount of light reaches the film. The reciprocity law applies to commonly available black-and-white and color films at exposure times from approximately  $1/10$  second to  $1/1,000$  second. This means that no adjustments are necessary for exposure or color in this shutter range. Most modern films however have increased this range to the point that no adjustments are necessary from approximately 1 second to  $1/10,000$  second. It should be pointed out that all photographic emulsions are subject to an effect often called "reciprocity-law failure." At exposure times at the edges of the above ranges, you will begin to see underexposure (loss of effective film speed) at the normally calculated exposure setting, a change in contrast, a color shift, or a combination of these effects. The word "failure," in this context, does not imply a short coming of the film, flash equipment or the camera, but merely that the reciprocity law does not hold for very long or very short exposures times.

We also sometimes refer to these changes in film response to particular illumination levels as "long-exposure effects" and "short-exposure effects."

## **LONG-EXPOSURE EFFECTS**

Under low-light conditions, you may have to extend your exposure times to a point of significant speed loss. With black-and-white films, the effect of this speed loss is partially offset by wide exposure latitude. Most color films require more than the normally calculated exposure when the lighting is unusually low. Also, the sensitivity differences between the many layers of color films can cause a color-balance shift, which means that you will sometimes need to use color-compensating filters to achieve an acceptable color balance.

When you must increase the indicated exposure to compensate for long-exposure effects, use a larger lens opening, if possible. Extending the exposure time will result in more speed loss, contrast change, and color shift. See the manufacturers data tables for your specific film to determine what exposure adjustment and filter may be necessary.

## **SHORT-EXPOSURE EFFECTS**

Extremely short exposures produce essentially the same effect as long exposures: speed loss. There is also an increased scattering of exposed silver halide grains, the formation of smaller latent-image centers, and a lower rate of development at the latent-image centers.

The short-exposure effect appears as lower contrast or reduced density in the negative. Exposures of 1/10,000 second or shorter can cause this problem.

## OPERATIONAL PARAMETERS

### Solair® Radio-Sync, Constant-Color PLR500DR Voltage Smart™ Radio-Sync, Constant Color PLRX500DR

#### Flashing Rate:

The unit recharges quickly, as indicated by the READY light on the control panel. A quick series of flashes can be obtained within the limits of the recharge time. Continuous rapid flashing, however, can overheat and damage the flashtube and internal parts. The maximum recommended rate of flashing would depend upon the power level being used and the amount of operation time. Use the following chart to serve as a guide for the maximum rate to use in your situation.

Power Level	Operating Time	Sec. Between Flashes.	Number of Flashes
Full	Continuous	8.3	Continuous
	11 Minutes	6	116
	4 Minutes	4	60
1/2	Continuous	4	Continuous
	4 Minutes	2	124
	1.4 Minutes	1	85
1/4	Continuous	2	Continuous

#### Exposure Information:

The following charts give the BCPS output for various umbrellas and reflectors. Coverage angle is given in degrees.

Umbrella Coverage	32 inch 120 degree	45 inch 120 degree	60 inch 120 degree
Full Power	5500	5583	5583
	2750	2792	2792
	1375	1396	1396
1/8	688	698	698
1/16	344	349	349
1/32	172	174	174
1/64	86	87	87
1/128	43	44	44

Reflector		PL7R	PL14R	PL16R	PL18RWD	PL24R
Diameter	None	7 "	14"	16"	18"	24"
Coverage	360°	35°	40°	60°	126°	145°
Full Power	2333	25000	17500	23333	3570	4200
	1167	12500	8750	11667	1785	2100
	583	6250	4375	5833	892	1050
1/8	292	3125	2188	2916	446	525
1/16	146	1562	1094	1458	223	262
1/32	73	781	547	729	112	131
1/64	37	391	274	365	56	66
1/128	18	195	137	182	28	33
GN@ASA100/10'	110	365	305	350	137	150

# SPECIFICATIONS

## Solair® Radio-Sync, Constant-Color PLR500DR Voltage Smart™ Radio-Sync, Constant Color PLRX500DR

### General:

Flash Power.....	3.9 to 500 watt-seconds. Maximum (8 f-stops)
Flash Duration.....	1/280 second at Full 1/5800 second at 1/128
Reciprocity.....	Excellent, no filters required
Recycling time.....	0.5 to 1.5 seconds @ full
Power Control.....	Full to 1/128 range. (8 f-stops) 0.1 f-stop resolution.
Color Temperatures.....	<±50°K over top 6 f-stops. <±100°K over entire 8 f-stops.
Modeling Light Power.....	250 Watt Quartz, ESS
Modeling Light Control.....	Full to 1/32 range. 0.1 f-stop resolution. Line voltage regulated.
Triggering.....	Built-in 16-channel radio receiver Built in Photoslave. Push to Test button. Synchronization Jack. 12 volt isolated.
Main Supply PLR500DR.....	105-125 VAC, 60 Hz, 5 amps.
Main Supply PLRX500DR.....	90-250 VAC, 50/60Hz, 3.5amp.
Consumption PLR500DR.....	0.2 amps idling, 15 amps charging.
Consumption PLRX500DR.....	0.2 amps idling, 5.5 amps charging.
Voltage Stabilization.....	Plus or minus 0.05 f-stop.
Packaging.....	Extruded Aluminum case.
Weight.....	5.8 pounds, (6.1 lbs. X500DR).
Dimensions PLR500DR (housing only).....	4.5" x 4.5" x 6.75"
PLRX500DR (housing only).....	4.5" x 4.5" x 9"

### Flashtubes and Modeling Lamps:

Flashtube.....	Plug-in style, use only Photogenic's C4-15C or C4-15D.
Modeling Lamp.....	250-Watt Quartz Halogen 150-Watt Quartz Halogen, ESP. 100-Watt Quartz Halogen, ESR.
Overload Protection Fuse PLR500DR.....	3AG type, 16 Amp, SLO-BLO.
Overload Protection Fuse PLRX500DR.....	5mmX 20mm, 8 Amp, SLO-BLO

# OPERATIONAL PARAMETERS

**Solair® Radio-Sync, Constant-Color PLR1000DR**  
**Voltage Smart™ Radio-Sync, Constant Color PLRX1000DR**

## Flashing Rate:

The unit recharges quickly, as indicated by the READY light on the control panel. A quick series of flashes can be obtained within the limits of the recharge time. Continuous rapid flashing, however, can overheat and damage the flashtube and internal parts. The maximum recommended rate of flashing would depend upon the power level being used and the amount of operation time. Use the following chart to serve as a guide for the maximum rate to use in your situation.

<b>Power Level</b>	<b>Operating Time</b>	<b>Sec. Between Flashes.</b>	<b>Number of Flashes</b>
Full	Continuous	17	Continuous
	7 Minutes	10	40
	2.5 Minutes	6	25
1/2	Continuous	8.3	Continuous
	4 Minutes	4	60
	1.4 Minutes	2	43
1/4	Continuous	4	Continuous

## Exposure Information:

The following charts give the BCPS output for various umbrellas and reflectors. Coverage angle is given in degrees.

<b>Umbrella Coverage</b>	<b>32 inch 120 degree</b>	<b>45 inch 120 degree</b>	<b>60 inch 120 degree</b>
Full Power	11000	11166	11166
	5500	5583	5583
	2750	2792	2792
1/8	1375	1396	1396
1/16	688	698	698
1/32	344	349	349
1/64	172	174	174
1/128	86	87	87

<b>Reflector</b>		PL7R	PL14R	PL16R	PL18RWD	PL24R
<b>Diameter</b>	None	7''	14''	16''	18''	24''
<b>Coverage</b>	360°	35°	40°	60°	126°	145°
Full Power	4666	50000	35000	46666	7140	8400
	2333	25000	17500	23333	3570	4200
	1167	12500	8750	11667	1785	2100
1/8	583	6250	4375	5833	892	1050
1/16	292	3125	2188	2916	446	525
1/32	146	1562	1094	1458	223	262
1/64	73	781	547	729	112	131
1/128	37	391	274	364	56	66
<b>GN@ASA100/10'</b>	160	515	430	495	194	210



# SPECIFICATIONS

## Solair® Radio-Sync, Constant-Color PLR1000DR Voltage Smart™ Radio-Sync, Constant Color PLRX1000DR

### General:

Flash Power.....	7.8 to 1000 watt-seconds maximum. (8 f-stops)
Flash Duration.....	1/250 second at Full 1/4000 second at 1/128
Reciprocity.....	Excellent, no filters required
Recycling time.....	0.8 to 3.0 seconds
Power Control.....	Full to 1/128 range. 0.1 f-stop resolution.
Color Temperatures.....	<±50°K over top 6 f-stops. <±100°K over entire 8 f-stops
Modeling Light Power .....	250 Watt Quartz, ESS
Modeling Light Control .....	Full to 1/32 range. 0.1 f-stop resolution. Line voltage regulated.
Triggering.....	Built-in 16-channel radio receiver Built in Photoslave. Push to Test button. Synchronization Jack. 12 volt isolated.
Main Supply PLR1000DR.....	105-125 VAC, 60 Hz, 5 amp.
Main Supply PLRX1000DR.....	90-250 VAC, 50/60Hz, 3.5amp.
Consumption PLR1000DR.....	0.2 amps idling, 15 amps charging.
Consumption PLRX1000DR.....	0.2 amps idling, 5.5 amps charging.
Voltage Stabilization .....	Plus or minus 0.05 f-stop.
Packaging .....	Extruded Aluminum case.
Weight .....	7 pounds. (7.8lbs X1000DR)
Dimensions PLR1000DR (housing only).....	4.5" x 4.5" x 8.75"
PLRX1000DR (housing only).....	4.5" x 4.5" x 11"

### Flashtubes and Modeling Lamps:

Flashtube .....	Plug-in style, use only Photogenic's C4-19C or C4-19D.
Modeling Lamp .....	250-Watt Quartz Halogen, E 150-Watt Quartz Halogen, ESP. 100-Watt Quartz Halogen, ESR.
Overload Protection Fuse PLR1000DR.....	3AG type, 16 Amp, SLO-BLO.
Overload Protection Fuse PLRX1000DR.....	5 X 20mm, 8 Amp, SLO-BLO

# **ADVANCED POWERLIGHT FEATURES**

**Solair® Radio-Sync, Constant-Color PLR500DR & PLR1000DR  
Voltage Smart™ Radio-Sync, Constant Color PLRX500DR & PLRX1000DR**

## **Automatic Discharge**

Each time the AC line power is disconnected or switched off, the unit will automatically flash-dump most of the stored power, and then discharge by resistor the remainder of the stored power. This removes all of the flash capacitor charge to prolong the life of the unit and is a much safer condition for storage, for transporting, and replacement of flash tube or modeling lamp. Even if the flash tube is defective or absent, the internal resistor will discharge all power within 20 seconds after the unit is turned off. This is a feature, over which the user has no control.

## **Unit Number Assignment**

This feature allows the user to assign a UNIT NUMBER (1 to 9) to each “DR” type PowerLight in the studio. The UNIT NUMBER is necessary when INFRARED remote control is used (see accessories.)

To assign a UNIT NUMBER, the startup sequence will need to be interrupted. Turn PowerLight AC power OFF. With the unit OFF press and hold the \_ stop “UP” button then turn the power switch to ON, continue holding the \_ stop button until the display reads “ir” then release the button. The Digital display should read “ir” when you press and release the \_ UP button again and the display will then read “Un - 1”, or some number 1 to 9. To change the UNIT number, press and release the 1/10 UP/DOWN arrow buttons until the desired number is displayed. To save and close the assignment feature and save the UNIT number, press and release the 1/2 UP arrow button again. This allows the startup sequence to finish and save the new settings. Each “DR” unit’s default unit number is set at “Un - 1”. You must re-set the unit number with the 1/10 adjustment buttons, or the default “Un 1” will automatically be assigned.

## **Wireless Setup.**

The “DR” units are pre-set for *Infrared* wireless operations at the factory and no adjustments are necessary for operation. Simply plug the PLDIR-2 into the port on the underside of the unit before turning the AC power ON.

*Infrared.* To adjust the infrared operation or assign a unit number, the startup sequence will need to be interrupted. With the unit OFF press and hold the \_ stop “UP” button then turn the power switch to ON, continue holding the \_ stop button until the display reads “ir” then release the button. The Digital display should read “ir” when you press and release the \_ UP button again and the display will read “Un - 1”, or some number 1 to 9. The next display is for unit number assignment. (See above)

During the “ir” display if you then press either of the 1/10 buttons you will display “rado” pressing the 1/10 button again will display a studio “Su” and number 1 through 4. Studio numbers are assigned with 1/10 buttons. NOTE: the “rado” is currently an internal-only system and **should not** be used if you intend to use infrared controls. To close “rado”, press the 1/10 button again until the display reads “ir” then press the \_ UP button again. The next display will be “Un 1” which is your light unit number 1 – 9 assignment. You must re-set the unit number with the 1/10 adjustment buttons, or the default “Un 1” will automatically be assigned. Once the unit number has been assigned press the \_ up button which allows the startup sequence to finish and save the new settings.

### **Diagnostic Display Codes:**

Circuits that prevent catastrophic damage to your investment protect the Solair and Voltage Smart Solair PowerLight units.

**“Er-0”** message means that an AC line power frequency problem has occurred. This could be internal or in the power cable or outlet at the location. Try turning the main power off wait for 5 seconds and turn power back on.

**“Er-1”** message means that an AC line power voltage problem has occurred. This could be internal or can happen with voltage spikes and voltage fall-off in the location power supply. Try turning the main power off wait for 5 seconds and turn power back on.

**“Er-3”** message means over heating has occurred. This could be internal or by exceeding the recommended flash frequency. (See flash rate chart) Once **“Er-3”** is displayed a **“COOL” mode** is activated to cool off internal components. This usually is caused by too many quick-discharges resulting in the overheating of the unit’s circuits. (See flash rate chart) The unit counts down in this COOL mode for approximately 4 minutes. This is an electronically timed period and turning the power OFF will not shorten this period. Therefore, you must leave the power ON during this COOL-DOWN cycle.

**“- - - -”** message means a misfire has occurred. To reset press the test fire button or turn the power OFF. If the “----“ continues, turn the unit off and have service performed. Examine the flash tube for damage as this can cause this misfire message to be illuminated.

# Advanced Series Accessories Solair<sup>®</sup>, Voltage Smart<sup>™</sup> & PL2 series

## **PLDIR-2 Remote digital display and Infrared receiver.** (Must be used with PLIRC controller)

The PLDIR-2 is a digital display to enhance visibility and to receive infrared signals to control the functions of the Solair Constant Color, Radio-Sync PowerLights. It displays Flash power, Modeling lamp power and unit number. It has a green READY indicator and a BI-color indicator for Flash or Model. Behind a small window is an infrared receiver. Resolution is 0.1 f-stop.

The PLDIR-2 may be mounted to the umbrella bracket under the housing of the PowerLight, on rotating mount, or on an extension cable, for better viewing and infrared control.

## **PLIRC-1 Infrared remote controller. (Must be used with PLDIR-2)**

Similar to TV, VCR, DTV universal remote controllers, the PLIRC-1 can control up to nine (9) PowerLights with individual settings. If several PowerLights are used with identical settings, the same unit number can be assigned to them. This will expand the total number of lights that can be controlled with the PLIRC-1. All panel button controls are available, plus STANDBY.

All Solair series PowerLights must have PLDIR-2 infrared receivers and have their unique unit numbers assigned. PowerLights may have identical unit number numbers, if they are to be operated exactly the same, under all studio arrangements.

Select a *Unit Number* on one of the top ten buttons, then control the PowerLight with the lower buttons, observing the PowerLight digital display for the changes.

The *All* button, under *Unit Number*, transmits the changes to all active PowerLights. This enables the photographer to raise or lower flash or model levels on all the units, without the laborious task of changing them all, individually.

STANDBY lets the photographer put all the PowerLights into a standby state to stop public photographers from slaving the units at a wedding, or some studio units can be put in standby when not required for a shot. The infrared control can easily reach to units on 12-foot stands (it has been tested to 100 feet, indoors.)

## **PLIBM-1 Studio System Controller software for IBM compatibles.** (Must be used with PLDIR-2 receivers.)

Along with infrared transmitter hardware and an IBM compatible computer, (using Windows 95, 98, 2000 or XP), the software is used by the photographer to specify the PowerLight settings for up to nine units with independent settings and save a studio setting or pose file. An unlimited number of pose files may be saved. All PowerLights must have PLDIR-2 infrared receivers.

# General Trouble Shooting

## COMMON PROBLEMS AND CAUSES

Unit does not charge. Probable causes:

1. Fuse blown. (Unplug the unit-Replace fuse.)
2. No line power to unit. (Check line cord and outlet.)
3. Internal thermal protection activated. Will occur if power setting is increased and decreased rapidly, several times. (Wait for unit to cool. May take 2 to 5 minutes.)

Modeling light does not turn on. Probable causes:

1. Lamp turned off. (Press FULL ON/OFF button until LED lights.)
2. Lamp burned out. (Inspect and replace, when cool. See SERVICE section of this manual)
3. Internal fuse blown, caused by shorted modeling lamp. (Factory service required.)

Light flashes by itself without apparent reason. Probable causes:

1. Defective trigger cord, or trigger cord incorrectly polarized.
2. Bright light falling on photo slave.
3. Poor connection in line cord.
4. Reverse connection on trigger cord connection at camera.
5. Some radio slaves will cause interference-consult slave manufacturer.

Trigger cord will not flash unit, but charge indicator shows that the system has charged.

Probable causes:

1. Defective trigger cord.

**Defective flashtube.** Turn unit OFF. Wait until cool, and then replace flashtube. (See SERVICE section of this manual)

**Infrared not working.** Probable causes:

1. Check for receiver model number to insure PLDIR-2 is being used and has been plugged into the PowerLight properly.
2. Turn unit power OFF and then back ON. The electronic startup sequence must detect the receiver is being used.
3. View the startup display sequence to insure “ir” is displayed. If “rado” is displayed see wireless setup in Advanced Features section.
4. If using the Hand-Held controller, press the unit number on the keypad before pressing any adjustment buttons. If using the Computer control, you must click transmit at the unit window or transmit-all at the top of the screen.

**Radio-Sync not working.** Probable causes:

1. Transmitter...wrong channel or batteries or connection to camera or defective.
2. Built-in receiver...wrong PowerLight model or defective.

## **Limited PowerLight® Warranty**

Photogenic Professional Lighting warranties the “standard line” products are free from defects in material and workmanship of the PL2 series of PowerLights for a period of two years from date of purchase. At our choice, we will repair or replace any PL2, Solair or Voltage Smart series light that is deemed to be defective. This warranty does not cover damages caused by shipping, product abuse or use other than the intended photographic applications.

Any product modifications will render this warranty void. Use of other manufacturer’s accessories, which restrict normal or intended operation (especially venting airflow), may cause damage and will void this warranty. Flash tubes are warranted under the above conditions for one year from date of purchase. Modeling lamps are covered for initial use failures only.

## **SERVICE**

The photographer should not attempt to make internal repairs.

Consult a dealer for an authorized Photogenic Professional Lighting service agent. This will provide you safety, insure proper operational functions and provide continuation of your warranty.

The technicians find it helpful to have the complete unit to better troubleshoot and evaluate any problems. This includes the light unit, the power cord, the flash tube and the modeling lamp.

For replacing the flashtube or modeling lamp, follow the directions and specifications given earlier in this manual in the setup section.

**Before removing the old tubes or installing new tubes**, always unplug your PowerLight to discharge the stored energy. Wait approximately 30 seconds for the main capacitors to deplete any residual stored voltage. Never place your fingers or any metal objects into the flash or modeling sockets. Contact with high voltage may result.

## **PowerLight® Infrared Studio-Control Accessories.**

(For all Digital Remote “DR” models.)

### **PLCPTR-2 Computer Studio Control System for IBM compatibles.**

- On-screen display of up to 9 different PowerLight “DR” models.
- Set and transmit commands to just one light or the entire studio.
- 360-degree command coverage for changing flash power, modeling intensity, proportional modeling sets, modeling ON/OFF, test flash, auto-bracketing and standby mode.
- Unlimited pose/light setting files can be named and saved for future recall when the same pose is repeated.

Includes: Proprietary software, RS232 connector, AC power adapter, and infrared dome transmitter. (Used with PLDIR-2 receivers sold separately)

### **PLIRC-1 Hand-Held infrared transmitter.**

- Set and transmit commands to just one light or the entire studio.
- Transmits commands for changing flash power, modeling intensity, proportional-modeling sets, modeling ON/OFF, test flash and standby mode. (Used with PLDIR-2 receivers sold separately)

Includes: Hand-Held transmitter and 9 volt battery.

### **PLDIR-2 Infrared receiver.**

- Displays the flash power in watt seconds or the modeling in watts.
- Receives the infrared signals from PLCPTR-2 and PLIRC-1 transmitters.
- Plugs into any Digital Remote “DR” model of PowerLights. (Used with PLIRC-1 and PLCPTR-2 transmitters sold separately)

Includes: Receiver/display and flexible cable to attach to PowerLights.

**POWERLIGHT® QUICK-CHANGE™**  
**ACCESSORIES**

**REFLECTORS:**

- PL3R -----3” Shallow Background reflector rotates to control light for high key and back lighting.
- PL3RV-----3” Veil **Slotted** Background reflector for veil and burst-lighting
- PL5R-----5” Deep Conical Background reflector.
- PL7R-----7 \_” Standard high grain reflector. 35-degree coverage.
- PL14R-----14” Parabolic for portraits, feathering, flood and fill lighting.  
45-degree coverage.
- PL16R-----16” Parabolic for portraits, feathering, flood and fill lighting.  
60-degree coverage.
- PL18R-----18” Parabolic for soft illumination and flood lighting.  
125-degree coverage.
- PL20R-----20” Parabolic for portraits, feathering, flood and fill lighting.  
65-degree coverage.
- PL24R-----24” Parabolic for soft illumination and flood lighting.  
145-degree coverage.

Additional PowerLight Light-Shaping Accessory items and Kits.

- Grids.
- Snoots.
- Soft Boxes.
- Barndoor Sets.
- Tilting Handle.
- Scrim & Gel rings.
- Eclipse Umbrellas.
- Counter-Balance weights.

Contact your local dealer for these and other Professional Photographic products by:

**Photogenic Professional Lighting**  
1268 Humbracht Circle, Bartlett, Illinois 60103-1631  
[www.Photogenicpro.com](http://www.Photogenicpro.com)  
Telephone: (630)830-2500 Fax: (630)830-2525  
MANUAL PART NO. 016577-00V0-6-05